

Application

The FD-150-OP fire damper employs airfoil blades for point-of-origin control of fire in static and dynamic HVAC systems. These specialty dampers are approved for installation with the closed plane of the blades up to 14½" (368) outside the fire rated partition and allow for direct service access from the face of the damper through the HVAC grille. The FD-150-OP is qualified to 3,000 ft/min (15.3 m/s) and 4 in.wg. (1.0 kPa) and may be installed in vertical walls or partitions, or horizontally in floors or assemblies with fire resistance ratings up to 2 hours.

Standard Construction

Frame: 5" × 1" (127 × 25) galvanized steel hat channel with interlocking corner gusset. Equivalent to 13 gauge (2.4) channel frame. Low profile head and sill are used on sizes less than 13" (330) high.

Blades: 6" × 14 gauge (152 × 2.0) equivalent galvanized steel airfoil.

Sleeve: 14" × 20 gauge (406 × 1.0) galvanized steel with 1" (25) flange and factory installed thermal insulation on four sides.

Axles: ½" (13) diameter plated steel hex.

Linkage: Concealed in frame.

Bearings: Stainless steel oilite, sleeve-type.

Seals: Silicone blade edge seals integrally rolled and mechanically fastened to blades. Flexible metal jamb seals.

Fire Closure Device: Fusible link.

Fire Closure Temperature: 165°F (75°C).

Minimum Size: 6" × 6" (152 × 152)

Maximum Size: 30" × 48" (762 × 1219)

Options

- PI-50 — Dual position indicator switch package.
- Alternate factory installed sleeve:
 - Gauge: 18 (1.3) 16 (1.6) 14 (2.0) 10 (3.5)
 - Net O.D. (sleeve I.D. will be approximately ⅜" (9) under nominal duct size opening).
- Transitions: Round: AR CR Oval: AO CO
 - Duct connections: 1" (25) S-clip 1½" (38) S-clip
 - DM25 DM35
- Alternate fire closure temperature:
 - 212°F (100°C) 250°F (121°C)
 - 286°F (141°C).
- Manual locking quadrant.

Ratings

UL 555 Fire Resistance Rating: 1½ hour (vertical and horizontal)

Maximum Dynamic Closure Velocity: 3,000 fpm (15.3 m/s)

Maximum UL555S Rated Pressure: 4 in.wg. (1.0 kPa)

Listings

UL 555 listing: R11767

CSFM listing: 3225-0368:110

New York City MEA listing: 295-98-E

Meets NFPA Standards: 90A, 92A, 92B and 101

Meets Building Code Standards: IBC, NBC, NFPA, SBC and UBC

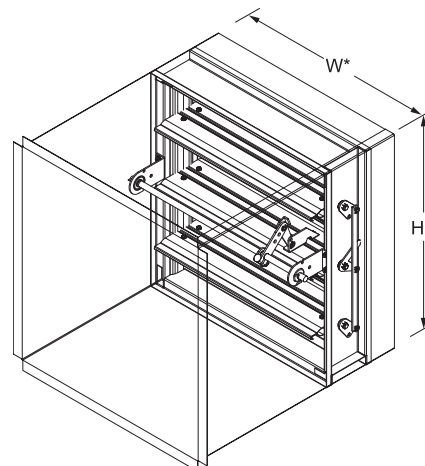

Model **FD-150-OP** (standard)

*Standard sleeve O.D. including thermal blanket wrap, is approximately ⅜" (9) over nominal duct size. Standard sleeve I.D. is approximately nominal duct size.

NOTE: The opening for the damper assembly in the fire wall must be sized appropriately. If not, serious damage to the thermal blanket wrap could occur and this will nullify the U.L. rating. Contact the factory if necessary for additional information.

Typical Damper Dimensional Data

The drawings and corresponding table show the position of the damper when mounted in a factory sleeve. The standard mounting locations provide enough space for installation of retaining angles and duct connections.

| Damper Height | J | X |
|---------------|--------|--------|
| <8" | 2" | 5-1/4" |
| ≥8" | 3-3/8" | 3-7/8" |

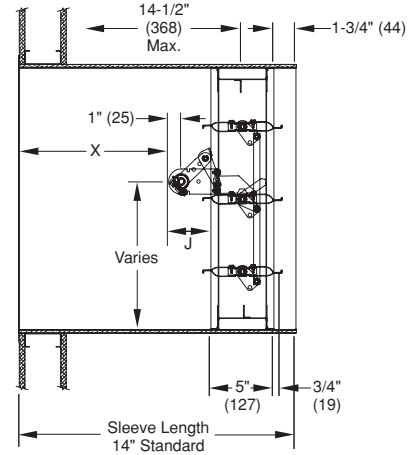
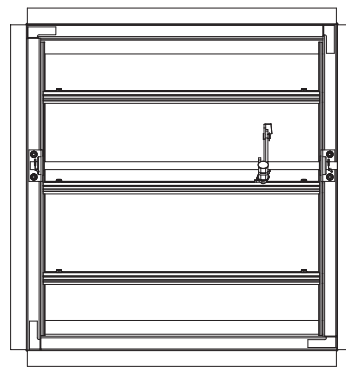

Airflow Performance Data

Pressure Loss vs. Velocity

Figure 5.3 — Ducted Inlet and Outlet

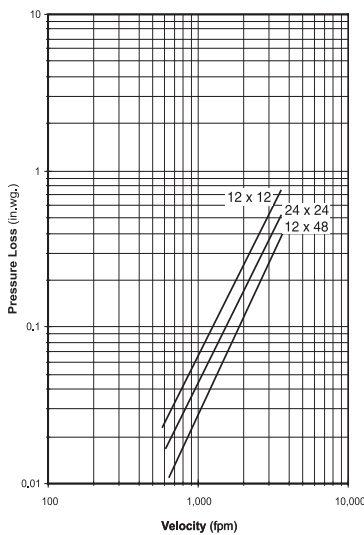

Figure 5.2 — Ducted Inlet

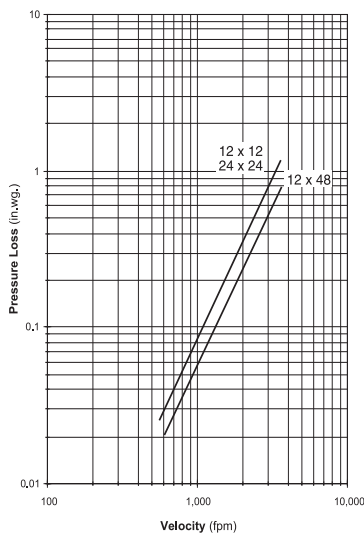
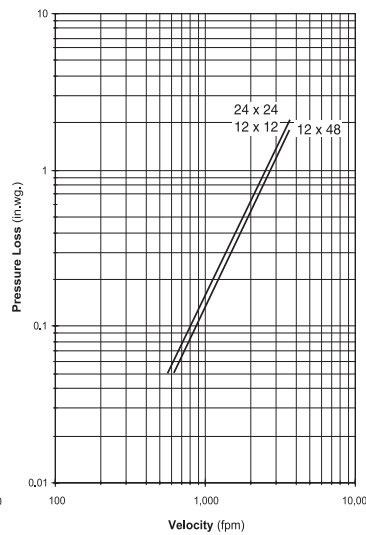
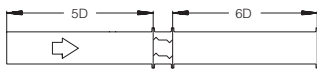

Figure 5.5 Plenum Mount



Pressure drop testing was performed in accordance with AMCA Standard 500-D using the three configurations shown. All data has been corrected to represent air density of 0.075 lb/ft. Actual pressure drop in any ducted HVAC system is a combination of many elements. This information, along with analysis of other system influences, should be used to estimate actual pressure losses for a damper installed in a given HVAC system.



Ducted Inlet and Outlet

AMCA Figure 5.3 illustrates a fully ducted damper. This configuration represents the lowest pressure drop of the three test configurations because entrance and exit losses are minimized by straight duct runs upstream and downstream of the damper.

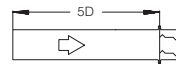

Ducted Inlet

AMCA Figure 5.2 illustrates a ducted damper exhausting air into an open area. This configuration has a lower pressure drop than Figure 5.5 because entrance losses are minimized by a straight duct run upstream of the damper.



Plenum Mount

AMCA Figure 5.5 illustrates a plenum mounted damper. This configuration has the highest pressure drop because of extremely high entrance and exit losses due to the sudden changes of area in the system.