



# FireDam™ Spray 100



Listed  
OPL ID# 15654-3



FILL OR VOID CAVITY  
MATERIALS CLASSIFIED BY  
UNDERWRITERS  
LABORATORIES, INC® FOR  
USE IN JOINT  
SYSTEMS (XHBN).  
SEE CURRENT UL FIRE  
RESISTANCE DIRECTORY

## Product Data

### 1. Product Description

3M™ FireDam™ Spray 100 is sprayable water-based material that dries to form a tough, elastomeric coating. This material firestops building joints, perimeter joints (curtain wall), and penetration seals. 3M FireDam Spray 100, when installed properly, will control the transmission of fire, heat, and smoke before, during, and after exposure to fire.

#### 3M FireDam Spray 100 Features

- Good adhesion to most construction materials
- Highly elastic--maintains performance with +/- 25% joint movement
- Broad range of applications--extensive portfolio of tested and listed building and perimeter joint systems
- Applied with conventional airless spray equipment
- Robust job site formula
  - Freeze/thaw resistant
  - Uniform seal formation in hot and cold drying conditions
- High cling properties--stays where it's sprayed
- Paintable
- Easy water clean-up

### 2. Applications

Ideal for sealing building joints, penetration seals, and perimeter joints. Helps limit the spread of noxious gas, smoke, and water. Maintains the integrity of the fire-rated construction.

### 3. Physical Properties

Product	Unit	Volume	Units/ Ctn.	Wt./ctn. Lbs.
FireDam Spray 100	5 gallon (18.9 litre)	1155.0 cu. in. (18926.9 cu. cm)	1	45.5 lbs. (20.6 kg)

### 4. Specifications

#### Product

The coating must be tested and listed by independent test agencies such as UL and Omega Point Laboratories. The coating shall comply with the requirements of BOCA, ICBO, SBCCI, and NFPA Code #101.

Building Joints: Must be fire tested and evaluated under the pass/fail criteria ASTM E 1966 and UL 2079 at maximum extended joint width. Joint must be cycled per ASTM E 1399 prior to test.

Perimeter Joints: Must pass under the pass/fail criteria of proposed ASTM "Standard Test Method for the Determining the Fire Endurance of Perimeter Fire Barrier Systems Using the Intermediate-Scale, Multi-Story Test Apparatus," capable of achieving a T-rating 1/4 hour, F-rating 2 hour, L-Rating <1scfm and +/- 16.7% movement.

Penetration Seals: Must be capable of passing ASTM E 814/UL 1479 Standard Method for Through-Penetration Firestops up to the desired fire resistance rating.

#### Typically Specified Divisions

Division 7	Thermal and Moisture Protection
07840	Firestopping
07842	Fire Resistive Joint Systems

## 5. Performance

### A. Typical Physical Properties

Base:	Polychloroprene
Color:	Light Green (wet), Emerald Green (dry)
Net Weight:	8.7 lbs./gal. (1.04 kg/litre)
Non-Volatile Content:	50%
Viscosity:	20,000 cps
Coverage*:	12.8 sq. ft./gallon (0.31 sq. m/litre)
Flash Point:	None
ASTM E 84:	Flame Spread: 0 Smoke Development: 0
Cure Time:	12 hrs tack-free
@70°F (21°C)/70% R.H.	48 hrs fully cured

\*The coverage rate listed is calculated coverage based on 1/8 in. (3 mm) thick wet coating.

### B. Firestopping Properties

Building Joints: Underwriters Laboratories Systems:  
HWD0020, HWD0021, HWD0022, HWD0023,  
HWD0029, HWD0030, HWD0031, HWD0038,  
HWD0040, HWD0101, HWD0122, HWD0123,  
HWD1010, FFD0002, FFD0014, FWD0004,  
FWD0011

Penetration Seals: Underwriters Laboratories  
System: CAJ1275

Perimeter Joints: Omega Point Laboratories  
Systems: CEJ113P, CEJ114P, CEJ115P, CEJ116P,  
CEJ119P, CEP120, CEJ121P, CEJ122P, CEJ123P,  
CEJ124P, CEJ125P, CEJ126P, CEJ158P, CEJ159P,  
CEJ160P, CEJ161P, CEJ162P, CEJ163P, CEJ164P,  
CEJ165P, CEJ166P, CEJ167P, CEJ168P, CEJ169P,  
CEJ234P, CEJ238P

### C. Firestopping Code Requirements

ICBO Uniform Building Code (1997 Edition)	SBCCI Standard Building Code (1997 Edition)	BOCA Basic/National Building Code (1996 Edition)	NFPA Life Safety Code 101 (1997 Edition)
702 DEFINITIONS	104.2.4 PLANS MUST SHOW HOW INTEGRITY IS MAINTAINED FOR ASSEMBLIES PENETRATED	702.0 REVISED AND EXPANDED DEFINITIONS FOR PENETRATIONS AND JOINTS	6-2.3.2.4 PENETRATIONS AND MISC. OPENINGS & FIRE BARRIERS
706 CONSTRUCTION JOINTS	202 DEFINITIONS	703.1 CONSTRUCTION DOCUMENTS SHALL INDICATE DETAILS AND MATERIALS FOR PROVIDING RATINGS AT JOINTS AND PENETRATIONS	6.2.4.2. EXCEPTION 5 OPENINGS (EXPANSION OR SEISMIC JOINTS) IN FLOORS
708 WOOD FRAME CONSTRUCTION FIREBLOCKING	705.3 WOOD FRAME CONSTRUCTION FIREBLOCKING	703.1.1 PENETRATIONS AND JOINTS SHALL NOT BE CONCEALED FROM VIEW BEFORE INSPECTION	APPENDIX A-6-2.4.2
709 WALL & PARTITION PENETRATION PROTECTION	705.3.1.5 CURTAIN WALL GAP	703.2 BUILDINGS FOR MORE THAN TWO STORIES SHALL INDICATE ALL PENETRATIONS	6-3.6.1 PENETRATIONS AND MISC. OPENINGS IN FLOORS AND SMOKE BARRIERS
709.3.2.2 CURTAIN WALL GAP	705.4 (GENERAL) PENETRATIONS OF FIRE RATED ASSEMBLIES	704.1.1 SUFFICIENT DATA SHALL BE AVAILABLE TO JUSTIFY UNTESTED MATERIALS USED FOR RESTORATION OF FIRE RATINGS	NFPA #221
710 FLOOR/CEILING OR ROOF/CEILING PENETRATION PROTECTION	705.5 (WALLS)	707.0 FIRE WALLS AND PARTY WALLS	FIRE WALLS AND BARRIERS
711.3 SHAFT ALTERNATIVE	705.6 (FLOORS)	707.10 PENETRATIONS - REFERS TO 714	
714 THROUGH-PENETRATION FIRESTOPS F&T REQUIREMENTS	705.7 FIRE RESISTANT JOINT SYSTEMS	707.8 JOINTS - REFERS TO 709.7	
UBC STANDARD 7-1 EQUIVALENT TO ASTM E 119		709.0 FIRE SEPARATION ASSEMBLIES	
UBC STANDARD 7-5 EQUIVALENT TO ASTM E 814		709.6 PENETRATIONS - REFER TO 714	
			NFPA Code 70 NEC National Electric Code
			300-21 FIRESTOPPING
			CABO One and Two Family Dwelling Code (1995 Edition)
			602.7 FIRESTOPPING (FIREBLOCKING IN OTHER MODEL CODES)

## 6. Installation Techniques

Shown is an example of a UL tested and listed system for 3M FireDam Spray 100. The appropriate tested and listed system must be used for each application. Additional details are available through your 3M authorized Fire Protection Products Distributor or sales representative.

1. Surface Preparation: Surfaces must be frost free, clean, dry and dust free.
2. Insulation: Cut 4 lb. density mineral wool to the contour of the joint adding 25% to each dimension so that the mineral wool can be tightly packed into the joint. The mineral wool should be flush with the face of the wall.
3. Coating: Apply the 3M FireDam Spray 100 using an airless sprayer to the joint overlapping onto the wall and floor a minimum 1/2 in. (13 mm). A minimum 1/8 in. (3 mm) wet coating should be applied over the mineral wool and substrates. 3M FireDam Spray 100 must be applied at a temperature between 40°F (4°C)

and 90°F (32°C). 3M FireDam Spray 100 can be applied when the ambient air temperature is 10°F (-12°C) or higher. Note: It is recommended that the pails of product remain in heated storage at 70°F (21°C) prior to spraying material in conditions below 40°F (4°C).

3M FireDam Spray 100 can be applied to surfaces that are 10°F (-12°C) providing that the surfaces are frost free, clean, dry and dust free.

The curing (evaporating of water) of the 3M FireDam 100 is affected by the ambient temperature and humidity. The lower the temperatures and the higher the humidity the slower the products will cure. At 70°F (21°C) and 70% R.H. a 1/8 in. thick wet coating is fully cured in 48 hours. Note: At temperatures below 32°F (0°C) no curing of the products will occur until the temperature of the installed product is above 32°F (0°C).

## 7. Spray Equipment

These procedures are intended to inform end users of the equipment requirements for properly

dispensing 3M FireDam Spray 100 and achieving the thickness and coverage necessary to comply with the tested systems for the product. The equipment mentioned is not an entire list of the pumps capable of delivering 3M FireDam Spray 100 but a sample of those known to be capable of accomplishing the desired results.

### General Equipment Parameters

Flow Output: 0.6 gpm minimum  
Liquid Pressure: 2000 psi minimum  
Tip Size Range: No. 219-231 (4 in. fan with 0.019-0.031 orifice)  
Motor Size: Greater than or equal to 0.75 horsepower

### Recommended Equipment

**Wagner:** SprayTECH® EP2400 and EP2510

**Graco:** Ultra® Max 695, 795, 1095 and 1595

**Titan:** Epic 660ex and 690gx, Elite E20 and G55

### Equipment Start-up

If the spray equipment has been used previously and has wash of a previous product, then purge the machine, hoses, and gun prior to spraying - do this as follows:

- Have a 5-gallon pail filled with five (5) gallons of clean water. This will be needed for clean-up at end of application.
- Turn on pump in prime (re-circulating mode). The pump should have a large and small tube. The large tube is a primary material pick-up tube, and small tube is the re-circulating tube.
- With pump in prime mode, place large pick-up tube in pail of clean water, leaving small re-circulating tube out of pail.
- As pump primes, water will be pushed out of system -- pump this water into another container. Continue to do this until a complete flow of clean water solution is attained.
- Drop re-circulating tube into pail of clean water solution.

### 3M FireDam Spray 100 2 hr. Gypsum Wallboard Fluted Steel Deck

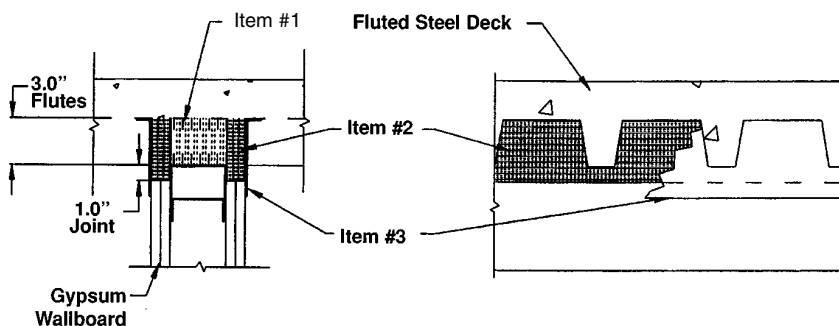

- Item #1: 4 lb. density mineral wool  
Cut the shape of the flutes
- Item #2: 4 lb. density mineral wool  
cut to the contour of the flutes and the joint
- Item #3: Minimum 1/8" (0.125")  
wet coating of 3M  
FireDam Spray 100

- Change pump from prime to spray mode. Hit the trigger of gun and hold open until clean water solution only comes out.
- Next turn pump back to re-circulating mode and drop large pick-up tube in pail of 3M FireDam Spray 100, while holding small re-circulating tube aside in another empty small pail or cup.
- As pump primes, you will pump clean water solution; then a combination of 3M FireDam Spray 100 and clean water solution and finally just 3M FireDam Spray 100.
- Change pump to spray mode hit spray trigger. As before, hold gun open until you have just 3M FireDam Spray 100 coming out.
- Then equipment is ready to spray.

#### **Equipment Clean-up/Shutdown**

To clean-up the gun, hoses, and spray machine a couple of clean plastic 5-gallon pails, a tooth-brush or other similar brush will be needed.

- First, place pump in re-circulating mode and remove both tubes from pail of 3M FireDam Spray 100. Using paper towel, wipe any excess spray off the outside of the pick-up and re-circulating tube.
- Have a minimum five (5) gallons of clean water in a five (5) gallon pail. Place the clean

water solution next to the pump and drop the large pick-up tube into the solution, while holding small re-circulating tube away from clean water solution.

- As machine comes to prime (out of small tube) 3M FireDam Spray 100 will come out first, then a combination of 3M FireDam Spray 100 and clean water solution, then finally just the cleaning solution and water.
- Now drop small tube in pail of the water solution and allow machine to re-circulate for a couple of minutes.
- Now change pump from prime (re-circulating) mode to spray mode and immediately hit trigger on spray gun.
- 3M FireDam Spray 100 will come out first then a combination of 3M FireDam Spray 100 and clean water solution and finally just clean water solution.
- Run the entire 5 gallons of water liquid through the machine.
- If the pump will not be used for a couple of days, an additional five (5) gallons of clean water solution needs to be circulated through the machine for ten (10) minutes.
- Use a toothbrush to clean-up the gun and spray tip.
- Follow pump manufacturer's recommendations for pump maintenance and storage.

"SprayTECH" is a trademark of Wagner  
"Ultra" is a trademark of Graco

## **8. Maintenance**

3M FireDam Spray 100 is stable under normal storage conditions. The product has a 12 month shelf life when stored at recommended temperature in the original, unopened container. Normal stock and stock rotation are recommended. Store at 40°F to 90°F (4°C to 32°C) for maximum shelf life. Higher temperatures can reduce shelf life.

## **9. Purchase Information**

3M FireDam Spray 100 is available from 3M Authorized Fire Protection Distributors. For information on where to buy, go to [www.3m.com/firestop](http://www.3m.com/firestop) or call (800) 328-1687.

## **10. Safe Handling Information**

**Consult Material Safety Data Sheet prior to handling and disposing of 3M FireDam Spray 100.**

#### **Warranty and Limited Remedy**

This product will be free from defects in material and manufacture for a period of ninety (90) days from date of purchase. **3M MAKES NO OTHER WARRANTIES INCLUDING, BUT NOT LIMITED TO, ANY IMPLIED WARRANTY OF MERCHANTABILITY OR FITNESS FOR A PARTICULAR PURPOSE.** User is responsible for determining whether the 3M product is fit for a particular purpose and suitable for user's method of application. If this 3M product is proved to be defective within the warranty period stated above, your exclusive remedy and 3M's sole obligation shall be, at 3M's option, to replace or repair the 3M product or refund the purchase price of the 3M product.

#### **Limitation of Liability**

**Except where prohibited by law, 3M will not be liable for any loss or damage arising from the use of this 3M product, whether direct, indirect, special, incidental or consequential, regardless of the legal theory asserted, including warranty, contract, negligence or strict liability.**



#### **Consumer Safety and Light Management**

3M Center 223-2N-21  
St. Paul, MN 55144-1000  
(800) 328-1687

Printed in U.S.A.

© 3M 2001 98-0400-5067-0 November 2001