



Fire Barrier Duct Wrap 15A

Duct Wrap Fire Protection Systems for Commercial Kitchen Grease and Chemical Exhaust Fume Ducts



NFPA 96
Compliance
1998 Edition

Complies with
International
Mechanical Code

Complies with
Standard
Mechanical Code

Product Data

1. Product Description

3M™ Fire Barrier Duct Wrap 15A is a fire resistant wrap consisting of a patented inorganic blanket encapsulated with a scrim-reinforced foil. It is used to fire rate commercial kitchen grease ducts and is a proven alternative to 1 or 2 hour fire resistant rated shaft enclosures. This mold resistant**, non-absestos wrap contains a safer fiber construction* and installs easily because of its high flexibility and strength. 3M Fire Barrier Duct Wrap 15A is a single layer fire resistant wrap that has passed the UL1978 test which simulates a grease duct fire. With its excellent insulating capabilities, it is an ideal choice for tight spaces because it protects combustible constructions at zero clearance throughout the entire enclosure system. 3M Fire Barrier 1000 N/S, 1003 S/L and 2000+ Silicone Sealants used in combination 3M Fire Barrier Duct Wrap 15A provide an effective firestop when the duct penetrates fire rated walls and floors.

Features

- One layer wrap for grease ducts rated as a shaft alternative per UL 1978
- Zero clearance to combustible throughout the entire enclosure system for congested spaces
- High flexibility for installation ease
- Foil encapsulated with unique center overlap seam for blanket protection, less dust, and high wrap strength
- Widest range of penetration seal systems
- Stitched edges
- Safer fiber construction*
- Mold resistant in accordance with ASTM C1338-00**

*Has been demonstrated to be soluble in the lungs according to EU guidelines 67/548/EWG, Note Q for bio persistence.

**Standard Test Method for Determining Fungi Resistance of Insulation Materials and Facings

2. Applications

3M Fire Barrier Duct Wrap 15A is an ideal fire resistive enclosure for commercial kitchen grease ducts. It is a proven performance alternative to a 1 or 2 hour fire resistant rated shaft enclosures and provides zero clearance to combustible construction throughout the entire enclosure system. 3M Fire Barrier 1000 N/S, 1003 S/L or 2000+ Silicone Sealant is used in combination with 3M Fire Barrier Duct Wrap 15A to firestop the duct when the duct penetrates fire rated floors and walls.

3. Availability

| Product | Unit | Size | Units/ ctn. | Wt./ ctn. |
|-------------------------------|------|---|----------------|-------------------|
| 3M Fire Barrier Duct Wrap 15A | Roll | 1.5 in. x 24 in. x 20 ft. (38mm x 60,9cm x 609 cm) | 1 | 53 lbs. 24 kg |
| 3M Fire Barrier Duct Wrap 15A | Roll | 1.5 in. x 48 in. x 20 ft. (38mm x 121 cm x 609 cm) | 1 | 106 lbs. 48 kg |

4. Typical Physical Properties

Blanket Color: gray/green
Weight: 1.38 lbs./sq. ft. (6.73 kg/sq. m)

5. Performance

3M Fire Barrier Duct Wrap 15A has been tested in accordance with the following:

| | |
|------------|----------------------------|
| ASTM C 411 | ASTM C 1338 |
| ASTM C 518 | ASTM E 136 |
| ASTM E 84 | ASTM E 814 |
| ASTM E 119 | UL 1978 (Sections 12 & 13) |

Surface Burning Characteristics (ASTM E 84)

Foil Encapsulated Blanket:

Flame Spread: 0
Smoke Developed: 0

Blanket:

Flame Spread: 0
Smoke Developed: 0

Thermal Conductivity

| Temperature °F (°C) | btu•in./(hr.•ft ² •F) |
|---------------------|----------------------------------|
| 500 (260) | 0.417 |
| 1000 (537) | 0.922 |
| 1500 (815) | 1.69 |
| 1800 (982) | 2.27 |

For technical data and properties of 3M Fire Barrier 1000 N/S, 1003 S/L and 2000+ Silicone Sealants see separate product data sheets available from your 3M representative or go to www.3m.com/firestop.

Grease Duct Listings

| Fire Resistive Rating | Enclosure System | Omega Point Lab. Design Nos. | |
|-----------------------|---|------------------------------|----------------------------|
| | | Duct System | Through-Penetration System |
| 1 or 2 hours | 1 layer of 3M Fire Barrier Duct Wrap 15A, 3 in. (76 mm) perimeter and longitudinal overlaps | GD 532 F 15A | FS 557 W |
| | | GD 538 F 15A | FS 558 F |
| | | GD 547 F 15A | FS 559 W |
| | | GD 548 F 15A | FS 560 F |
| | | GD 549 F 15A | FS 561 F |
| | | GD 556 F 15A | FS 562 W |
| | | GD 557 F 15A | FS 563 W |
| | | | FS 578 F |
| | FS 579 W | | |

Chemical Exhaust Fume Duct Listings

| Fire Resistive Rating | Enclosure System | Omega Point Lab. Chemical | |
|-----------------------|---|---------------------------|----------------------------|
| | | Duct System | Through-Penetration System |
| 1 or 2 hours | 1 layer of 3M Fire Barrier Duct Wrap 15A, 3 in. (76 mm) perimeter and longitudinal overlaps | CFD500F 15A | FS 557 W 15A |
| | | CFD501F 15A | FS 558 F 15A |
| | | | FS 559 W 15A |
| | | | FS 560 F 15A |
| | | | FS 561 F 15A |
| | | | FS 562 W 15A |
| | | | FS 563 W 15A |
| | | | FS 578 F 15A |
| | | | FS 579 F 15A |

Product Approvals

Product Approvals

ICC ES Compliance Legacy Report 2161
 ICC ES Compliance Legacy Report 2132A
 New York City MEA; 147-01-M
 California State Fire Marshall; 2440-0941:110

Code Compliance

3M Fire Barrier Duct Wrap 15A complies with requirements of the following codes:

NFPA 96, 1998 Edition
 1997 Standard Mechanical Code
 1998/2000 International Mechanical Code
 1999 BOCA National Building Code
 1999 Standard Building Code

This is only a partial list of code compliance. For the latest code and approval information go to www.3m.com/firestop or speak to your authorized 3M distributor or sales representative at (800) 328-1687.

6. Installation Techniques

3M Fire Barrier Duct Wrap 15A system should be installed in accordance with the following installation instructions.

Material and Equipment

- 3M Fire Barrier Duct Wrap 15A blanket, 1-1/2 in. (38 mm) thick, 24 in. (60 cm) or 48 in. (121 cm) wide, 20 ft. (609 cm) standard length. The 48 in. (121 cm) wide blanket helps to minimize waste.
- Aluminum foil tape.
- Minimum 3/4 in. (19 mm) wide filament tape.
- Carbon steel or stainless steel banding material, minimum 1/2 in. (12,7 mm) wide, minimum 0.015 in. (0,38 mm) thick, with steel banding clips.
- Hand banding tensioner, crimping tool, and banding cutter.
- Minimum 12 gauge copper-coated steel insulation pins; galvanized steel or stainless speed clips, minimum 1-1/2 in. (38 mm) square or 1-1/2 in. (38 mm) dia. round, or equivalent sized insulated cup-head pins; capacitor discharge stud gun.
- Access door hardware: four galvanized steel thread rods, 1/4 in. (6 mm) diameter by 4-1/2 in. to 5 in. long (114 mm to 127 mm) with 1/4 in. (6 mm) wing nuts and 1/4 in. (6 mm) washers; 4 in. (102 mm) long steel hollow tubing to fit threaded rods.
- Minimum 4.0 lb. (1,8 kg) density mineral wool or scrap pieces of 3M Fire Barrier Duct Wrap 15A.
- 3M Fire Barrier 1000 N/S, 1003 S/L or 2000+ Silicone Sealant.

Storage: The 3M Fire Barrier Duct Wrap 15A and 3M Fire Barrier 1000 N/S, 1003 S/L and 2000+ Silicone Sealants must be stored in a dry warehouse environment. Pallets should not be stacked.

Preparatory Work: 3M Fire Barrier Duct Wrap 15A is installed with common tools, such as knives, banders and capacitor discharge guns for applying insulation pins. In order to install the duct firestop system, the surfaces of all the openings and penetrating items need to be clean, dry, frost free and free of dust.

Method: To minimize waste, 3M Fire Barrier Duct Wrap 15A material should be rolled out tautly before measuring. General instructions for installing the 3M Fire Barrier Duct Wrap 15A include a one-layer wrap construction applied directly to the duct. The 3M Fire Barrier Duct Wrap 15A blanket is wrapped around the perimeter of the duct and is cut to a length to overlap itself not less than 3 in. (76 mm). The overlap made by adjacent blankets forms the “longitudinal” overlap. Aluminum foil tape is used to seal all cut edges of the blanket and any tears in the foil scrim.

There are three (3) approved installation techniques for installing the 3M Fire Barrier Duct Wrap 15A (See Figure 1):

1. Telescoping 3 in. (76 mm) Overlap Wrap

With the telescoping overlap wrap method, each blanket overlaps one adjacent blanket, and each blanket has one edge exposed and one edge covered by the next blanket as shown in Figure 1. The visible edges of the perimeter overlaps all point in the same direction.

2. Checkerboard 3 in. (76 mm) Overlap Wrap

With the 3 in. (76 mm) checkerboard overlap wrap method, blankets with both edges exposed alternate with blankets with covered edges, as shown in Figure 1. The visible edges of the perimeter overlaps alternate their directions and appear on every other blanket.

3. Butt Joint With Collar

With the butt joint and collar method, adjacent blankets are butted tightly together and 6 in. (152 mm) wide collar of 3M Fire Barrier Duct Wrap is centered over the joint, overlapping each blanket by 3 in. (76 mm) minimum as shown in Figure 1.

In all three overlap techniques the perimeter overlap can occur at any location on the duct.

The blanket is mechanically attached to the duct by steel banding or by welded insulation pins and clips for all three installation methods listed above.

For Banding Only (See Figure 1)

Filament tape can be used to temporarily hold the blanket in place until the banding is applied. The steel banding is applied around the duct 1-1/2 in. (38 mm) from each edge of the blanket, and maximum 10-1/2 in. (26,7 cm) centers. The banding is placed around the material and tightened so as to sufficiently hold the 3M Fire Barrier Duct Wrap 15A in place against the duct, compressing the foil but not cutting the foil.

Additional Pinning to Prevent Sagging of the Wrap:

For Ducts 24 in. (60 cm) and larger in width, additional pins are needed to support the blanket on the bottom horizontal surface and on the outside face of a vertical duct run. Space pins a maximum of 10-1/2 in. (26,7 cm) apart in the direction of the blanket width, and a maximum of 12 in. (30 cm) apart in the direction of the blanket length. Refer to paragraph below for more information on Mechanical Fastening with Pins.

For Mechanical Fastening with Pins Only

Insulation pins are welded to the duct in the centers of the overlaps a minimum of 1-1/2 in. (38 mm) from each edge of the blanket, and spaced a maximum of 10-1/2 in. (26,7 cm) on center along perimeter overlap, and a maximum of 10-1/2 in. (26,7 mm) on center along longitudinal overlaps. The blanket is impaled over the pins and held in place by galvanized speed clips. Insulation pins that extend beyond the blanket wrap shall be turned down to eliminate sharp points. Insulated cup-head pins can be used at the same spacing requirements of the insulation pins.

NOTE: Support hangar systems do not need to be wrapped provided the hangar rods are at least a minimum of 3/8 in. (9,53 mm) diameter and spaced a maximum of 60 in. (152 cm) on center along the length of the duct. Use a minimum 2 in. x 2 in. x 1/4 in. (50 mm x 50 mm x 6,35 mm) steel angle steel support channel or SMACNA equivalent support system.

Access Door Installation (See Figure 2)

Four galvanized steel threaded rods, 1/4 in. diameter (6,35 mm) by 4-1/2 in. to 5 in. long (114 mm to 127 mm) are welded to the duct at the corners of the door opening. Four steel tubes, each 3 in. (76 mm) long, are placed over the rods to act as protection for the 3M Fire Barrier Duct Wrap 15A when fastening the door. Four insulation pins are welded to the door panel for installation of the blanket. One layer of 3M Fire Barrier Duct Wrap 15A is cut approximately the same size as the access panel and impaled over the insulation pins on the panel. *It is essential that this layer fit*

tightly against the wrap surrounding the access door opening with no through openings. A second layer of 3M Fire Barrier Duct Wrap 15A is cut so as to overlap the first layer by a minimum of 1 in. (25,4 mm). The second layer is impaled over the pins and both layers are locked in place with galvanized speed clips. Pins that extend beyond the outer layer of 3M Fire Barrier Duct Wrap 15A shall be turned down to avoid sharp points on the door.

The insulated door panel is placed over the threaded rods and held in place with washers and wing nuts. The details are shown in Figure 2.

Penetrations (See Figure 3)

When the duct penetrates a fire rated wall, ceiling or floor, an approved firestop system must be employed. Figure 3 illustrates a typical condition.

To firestop the wrapped duct, follow the installation parameters detailed in the following Omega Point Laboratories, Inc. systems:

FS 557 W, FS 558 F, FS 559 W, FS 560 F, FS 561 F, FS 562 W, FS 563 W, FS 578 F, FS 579 W.

Other Applications

More details on the installation of the product can be found in the 3M Product Data and Installation Instruction Manual (98-0400-5054-8).

7. Maintenance

No maintenance is required when installed in accordance with the 3M Installation Instructions. Once installed, if any section of the 3M Fire Barrier Duct Wrap 15A is damaged so that the blanket is damaged,

Figure 1
3M Fire Barrier Duct Wrap 15A Commercial Kitchen Grease Duct Systems
1 or 2 Hour Shaft Alternative Zero Clearance to Combustibles
Telescoping Wrap Technique With Banding For Ducts 24 inches (60,9 cm) or Less

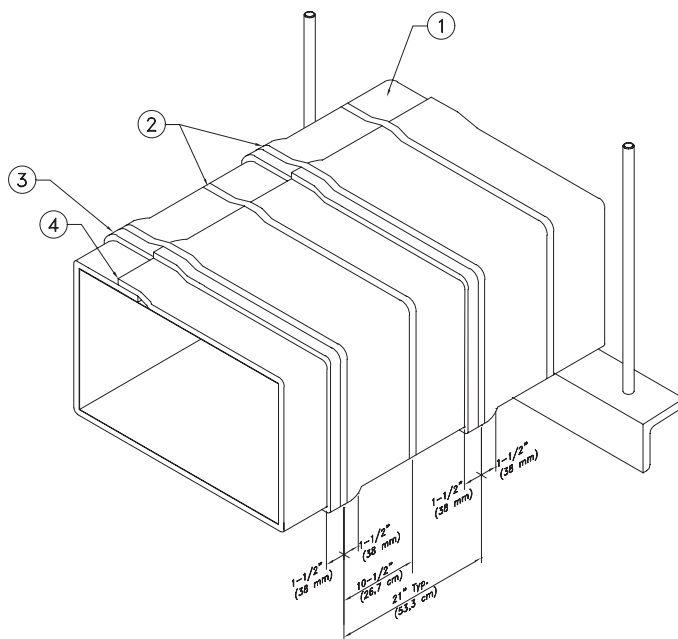

Telescoping Overlap Wrap Option

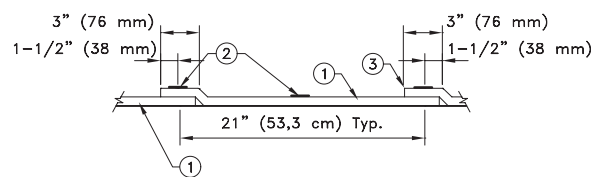

Checkerboard Overlap Wrap Option

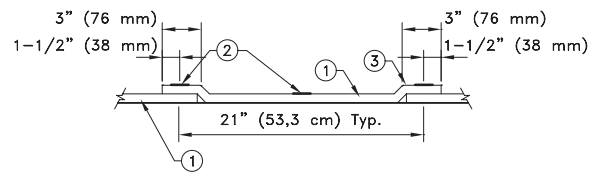

Butt Joint With Collar Option

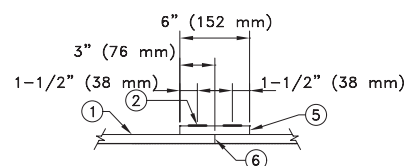

| | |
|----|---|
| 1. | One Layer 3M Fire Barrier Duct Wrap 15A |
| 2. | Steel Banding 1/2 in. (13 mm) Wide Min. Typical |
| 3. | 3 in. (76 mm) Min. Longitudinal Overlap |
| 4. | 3 in. (76 mm) Min. Perimeter Overlap |

System integrity is limited by quality of installation.

the following procedures will apply:

- The damaged section should be removed by cutting the steel banding or removing the clips holding it in place.
- A new section of the same dimension should be cut from a roll of 3M Fire Barrier Duct Wrap 15A, either 24 in. (60,9 cm) or 48 in. (121 cm) wide.
- The new section should be placed and fitted ensuring the same overlap that existed previously.
- The steel banding should be placed around the material and tensioned so as to sufficiently hold the 3M Fire Barrier Duct Wrap 15A in place.

Figure 2
3M Fire Barrier Duct Wrap 15A
Commercial Kitchen Grease Duct Systems
1 or 2 Hour Access Door System

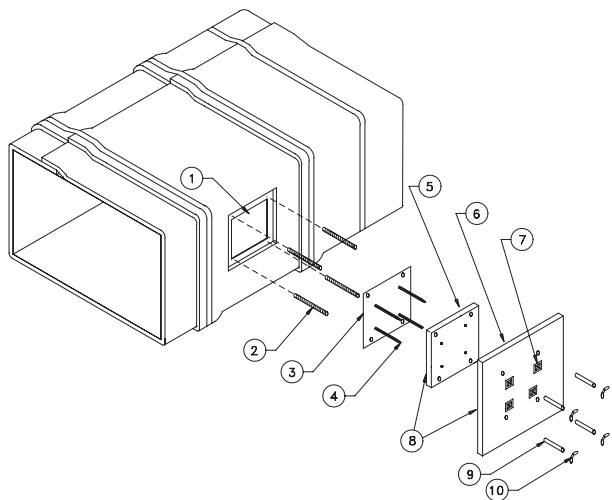

| | |
|-----|---|
| 1. | Access Hole |
| 2. | 1/4 in. (6 mm) Dia. All Threaded Rods |
| 3. | Access Cover – 16 Gauge |
| 4. | Insulation Pins – Welded |
| 5. | First Layer 3M Fire Barrier Duct Wrap 15A Cut Same Size As Cover |
| 6. | Second Layer 3M Fire Barrier Duct Wrap 15A with 1 in. (25mm) Overlap On All Sides |
| 7. | Speed Clips |
| 8. | Aluminum Tape Covering All Exposed Edges |
| 9. | Spool Pieces For Threaded Rods |
| 10. | 1/4 in. (6mm) Diameter Wing Nuts |

System integrity is limited by quality of installation.

Warranty and Limited Remedy. This product will be free from defects in material and manufacture for a period of ninety (90) days from date of purchase. **3M MAKES NO OTHER WARRANTIES INCLUDING, BUT NOT LIMITED TO, ANY IMPLIED WARRANTY OR MERCHANTABILITY OR FITNESS FOR A PARTICULAR PURPOSE.** User is responsible for determining whether the 3M product is fit for a particular purpose and suitable for user's method of application. If this 3M product is proved to be defective within the warranty period stated above, your exclusive remedy and 3M's sole obligation shall be, at 3M's option, to replace or repair the 3M product or refund the purchase price of the product.

Limitation of Liability. Except where prohibited by law, 3M will not be liable for any loss or damages arising from the use of this 3M product, whether direct, indirect, special, incidental or consequential, regardless of the legal theory asserted, including warranty, contract, negligence or strict liability.



Building Safety Solutions Department

3M Center 223-2S-24
 St. Paul, MN 55144-1000
 Phone 800-328-1687
 Fax 888-362-2737
 www.3m.com/firestop

- If the blanket has not been damaged but the foil has ripped, seal the rips with aluminum foil tape.

8. Purchase Information

3M Fire Barrier products are available through a network of nationwide distributors. For information on where to buy, go to www.3m.com/firestop.

9. Safe Handling Information

Consult Material Safety Data Sheet prior to handling and disposing of 3M Fire Barrier Duct Wrap 15A.

Figure 3
3M Fire Barrier Duct Wrap 15A
Commercial Kitchen Grease Duct Systems
1 or 2 Hour Through Penetration Systems
4-1/2 inch (11,4 cm) Concrete Floor or Wall

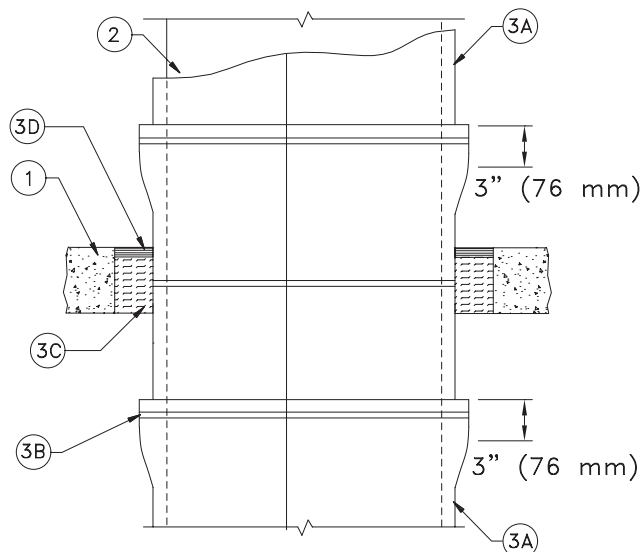

| | |
|-----|--|
| 1. | Floor/Ceiling or Wall Assembly |
| 2. | Duct |
| 3A. | One Layer 3M Fire Barrier Duct Wrap 15A |
| 3B. | Banding or Pinning |
| 3C. | Packing Material |
| 3D. | 3M Fire Barrier 1000 N/S, 1003 S/L or 2000+ Silicone Sealant For Wall Assembly Apply Sealant To Both Sides of Wall |

System integrity is limited by quality of installation.