



Fire Barrier Duct Wrap 615+

Duct Wrap Fire Protection System for Commercial Kitchen Grease and Ventilation Air Ducts

Product Data



1. Product Description

3M™ Fire Barrier Duct Wrap 615+ is a fire resistant wrap consisting of an inorganic fiber blanket encapsulated with a scrim-reinforced foil. The product is 1-1/2 in. thick, 6pcf density.¹ It is used to fire rate commercial kitchen grease ducts as well as ventilation ducts, and is a proven alternative to 1 or 2 hour fire resistant rated shaft enclosures. With its excellent insulating capabilities, low weight and thin profile, it is an ideal choice for a duct enclosure system. This non-asbestos wrap installs easily because of its high flexibility and strength.

Features

- Two-layer wrap for grease ducts rated as a shaft alternative per ASTM E 2336
- Zero clearance to combustible throughout the entire enclosure system for congested spaces
- One-layer wrap for fire-resistive ventilation ducts per ISO 6944
- High flexibility for installation ease
- Foil encapsulated for blanket protection, less dust, and high wrap strength
- Widest range of penetration seal systems

2. Applications

Two-layer applications of 3M™ Fire Barrier Duct Wrap 615+ meet the criteria of ASTM E 2336 ‘Standard Test Methods for Fire Resistive Grease Duct Enclosure Systems’.

3M™ Fire Barrier Duct Wrap 615+ as single-layer fire resistant wrap application has passed the ISO 6944 ‘Fire Resistance Tests – Ventilation Ducts’.

3M™ Fire Barrier Duct Wrap 615+ is an ideal fire resistive enclosure for commercial kitchen grease ducts and ventilation air ducts. It is a proven performance alternative to a 1 or 2 hour fire resistant rated shaft enclosures and provides zero clearance to combustible construction throughout the entire enclosure system. 3M™ Fire Barrier Water Tight Sealant 1000 NS, 3M™ Fire Barrier Water Tight Sealant 1003 SL or 3M™ Fire Barrier Water Tight Sealant 2000+ Silicone Sealants is used in combination with 3M™ Fire Barrier Duct Wrap 615+ to firestop the duct when the duct penetrates fire rated floors and walls.

3. Availability

Unit	Size	Quantity	Weight
Roll	24 in. x 25 ft. (60,9 mm x 635 cm)	1	45 lbs (20.4 kg)
Roll	48 in. x 25 ft. (121 cm x 635 cm)	1	90 lbs (40.8 kg)

4. Typical Physical Properties

Blanket Color	Weight
White	0.9 lbs./ft. ² (4.38 kg/m ²)

¹ In accordance with the tolerances in ASTM C 892 Standard Specification for High-Temperature Fiber Blanket Thermal Insulation.

5. Performance

A. 3M™ Fire Barrier Duct Wrap 615+ has been tested in accordance with the following:

ASTM E 2336	Standard Test Methods for Fire Resistive Grease Duct Enclosure Systems
ASTM E 119	Standard Test Methods for Fire Tests of Building Construction and Materials
ASTM E 814	Standard Test Method for Fire Tests of Through-Penetration Fire Stops
ASTM E 136	Standard Test Method for Behavior of Material in a Vertical Tube Furnace at 750°C (1382°F)
ASTM C 518	Standard Test Method for Steady-State Thermal Transmission Properties by Means of the Heat Flow Meter Apparatus
ASTM C 1338	Standard Test Method for Determining Fungi Resistance of Insulation Materials and Facings
ASTM E 84	Standard Test Method for Surface Burning Characteristics of Building Materials
ISO 6944-85	Fire Resistance Tests – Ventilation Ducts

B. Surface Burning Characteristics (ASTM E 84, ULC/CAN S-102)

	Flame Spread	Smoke Developed
Foil Encapsulated Blanket	<25	<50

F. Design Listings

Fire Resistive Rating	Enclosure System	Third-Party Testing Services Design Listing	Description
Grease Duct Listings – ASTM E 2336			
1 and 2 Hour	2 layers of 3M™ Fire Barrier Duct Wrap 615+, minimum 3 in. (76 mm) perimeter and longitudinal overlaps	Intertek 3MU/FRD 120-18	48 x 48 in. Rectangular
		Intertek 3MU/FRD 120-19	48 in. Round
Ventilation Duct Listings – ISO 6944			
1 and 2 Hour	1 layer of 3M™ Fire Barrier Duct Wrap 615+, minimum 3 in. (76 mm) perimeter and longitudinal overlaps	Intertek 3MU/FRD 120-15 Underwriters Laboratories HNLJ.V-27	24 x 85 in. Rectangular
		Intertek 3MU/FRD 120-04	40 in. Round

G. Codes and Standards

3M™ Fire Barrier Duct Wrap 615+ installed per ASTM E 2336 tested Design Listings meets the requirements of the following codes:

NFPA 96, 2008 Edition
2006/2009 International Mechanical Code

3M™ Fire Barrier Duct Wrap 615+ installed per ISO 6944 tested Design Listings can be utilized to meet the requirements of the following codes:

NFPA 92A Standard for Smoke-Control System Utilizing Barriers and Pressure Differences, 2006 Edition – Section 6.6.2

NFPA 92B Standard for Smoke Management Systems in Malls, Atria, and Large Spaces, 2005 Edition – Section 7.5.2

NFPA 101® Life Safety Code®, 2006 Edition – Section(s) 8.6.7, 18.7.7

International Mechanical Code®, 2006 Edition – Section 513.10.2

International Building Code®, 2006 Edition – Section 909.10.2

C. Thermal Conductivity

Temp.	$\frac{Btu - in.}{hr - ft^2 - ^\circ F}$	$\frac{W}{m^2 - K}$
500°F (260°C)	0.48	0.07
1000°F (537°C)	0.97	0.14
1500°F (815°C)	1.57	0.23
1800°F (982°C)	1.98	0.29
2000°F (1093°C)	2.23	0.33

D. Linear Shrinkage

24 Hr @ 2012°F (1000°C): 1.2%

E. R-Value

Single layer of 3M™ Fire Barrier Duct Wrap 615+ at 77°F (25°C):

$$6.38 \frac{^\circ F - ft^2 - hr}{Btu}$$

These are only partial lists for design listings and code requirements. For the latest code and approval information go to www.3M.com/firestop or speak to your authorized 3M distributor or sales representative at (800) 328-1687.

6. Installation Techniques

3M™ Fire Barrier Duct Wrap 615+ should be installed per the application design listing in accordance with the following basic installation instructions.

A. Material and Equipment

- 3M™ Fire Barrier Duct Wrap 615+ blanket, 1-1/2 in. (38 mm) thick², 24 in. (60 cm) or 48 in. (121 cm) wide, 25 ft. (635 cm) standard length. The 48 in. (121 cm) wide blanket helps to minimize waste.
- Aluminum foil tape.
- Minimum 3/4 in. (19 mm) wide filament tape.
- Stainless steel banding material, minimum 1/2 in. (12,7 mm) wide, minimum 0.015 in. (0,38 mm) thick, with stainless steel banding clips.
- Hand banding tensioner, crimping tool and banding cutter.
- Minimum 12 gauge copper-coated steel insulation pins used with minimum 2-1/2 in. (38 mm) square galvanized steel or stainless steel clips or 1-1/2 in. (38 mm) dia. round or equivalent sized insulated cup-head pins.
- Capacitor discharge stud gun.
- Access door hardware: four galvanized steel thread rods, 1/4 in. (6 mm) diameter by minimum 6 in. long (152 mm) with 1/4 in. (6 mm) wing nuts and 1/4 in. (6 mm) washers.
- 4 in. (102 mm) long steel hollow tubing to fit threaded rods.
- Minimum 4 pcf (64 kg/m³) density mineral wool or scrap pieces of 3M™ Fire Barrier Duct Wrap 615+.
- 3M™ Fire Barrier Water Tight Sealant 1000 NS, 1003 SL or 3M™ Fire Barrier Silicone Sealant 2000+.

B. Storage

The 3M™ Fire Barrier Duct Wrap 615+ and 3M™ Fire Barrier Water Tight Sealant 1000 NS, 1003 SL or 3M™ Fire Barrier Silicone Sealant 2000+ must be stored in a dry warehouse environment. Pallets should not be stacked.

C. Preparatory Work

3M™ Fire Barrier Duct Wrap 615+ is installed with common tools, such as knives, banders and capacitor discharge guns for applying insulation pins. In order to install the duct firestop system, the surfaces of all the openings and penetrating items need to be clean, dry, frost free and free of dust.

D. Method (Two-Layer for ASTM E 2336)

Note: These general instructions for installing 3M™ Fire Barrier Duct Wrap 615+ include a two-layer wrap construction of 24-inch 3M™ Fire Barrier Duct Wrap 615+ blanket applied directly to a grease duct. To minimize waste, 3M™ Fire Barrier Duct Wrap 615+ material should be rolled out tautly before measuring. The first layer of 3M™ Fire Barrier Duct Wrap 615+ blanket is wrapped around the perimeter of the duct and is cut to a length to overlap itself not less than 3 in. (76 mm). The overlap made by adjacent blankets forms the “longitudinal” overlap. Aluminum foil tape is used to seal all cut edges of the blanket and any tears in the foil scrim. This first layer is temporarily held in place using filament tape. The first layer does not require stainless steel banding.

The second layer of 3M™ Fire Barrier Duct Wrap 615+ blanket is wrapped around the perimeter of the previously installed first layer of 615+, and is cut to at length to overlap itself not less than 3 in. (76 mm). The centerline of the second layer of blanket should be centered over the overlap of the first layer. The second layer of blanket requires longitudinal overlap onto adjacent blankets of not less than 3 in. (76 mm). The second layer of blanket is also held in place using filament tape. The second layer of wrap requires permanent fastening with stainless steel banding or rows of weld pins (impaling or cup-head style).

² In accordance with the tolerances in ASTM C 892 Standard Specification for High-Temperature Fiber Blanket Thermal Insulation.

Figure 1

3M™ Fire Barrier Duct Wrap 615+ Commercial Kitchen Grease Duct Systems 1 or 2 Hour Shaft Alternative Zero Clearance to Combustibles Telescoping Wrap Technique With Banding For Ducts 24 inches (60,9 cm) or Less

1. First Layer 3M™ Fire Barrier Duct Wrap 615+
2. Second Layer 3M™ Fire Barrier Duct Wrap 615+
3. 3/4 in. (19 mm) Wide Filament Tape
4. Steel Banding 1/2 in. (13 mm) Wide Min.
Typical for Permanent Fastening
5. 3 in. (76 mm) Min. Longitudinal Overlap
6. 3 in. (76 mm) Min. Perimeter Overlap

System integrity is limited by quality of installation.

Ducts > 24 in. (60,9 cm) Wide Require Pinning on the Bottom Side.

Consult Current Independent Testing Laboratories (Intertek, UL) For Design or System Details.

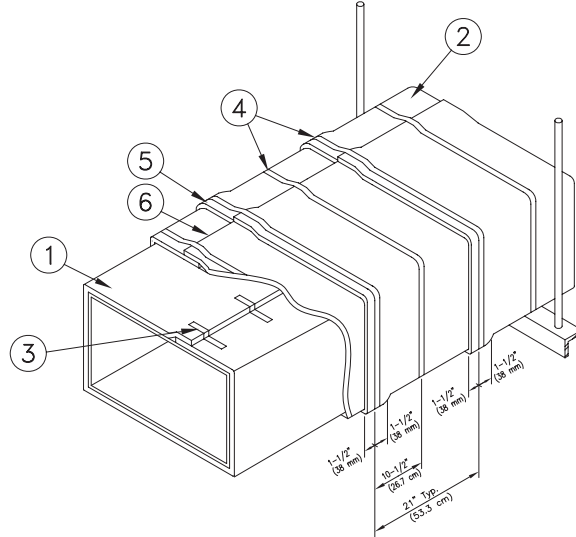

There are three (3) approved installation techniques for installing the 3M™ Fire Barrier Duct Wrap 615+ (See Figures 1A, 1B, & 1C):

1. Telescoping 3 in. (76 mm) Overlap Wrap Cross Section View

With the telescoping overlap wrap method, each blanket overlaps one adjacent blanket, and each blanket has one edge exposed and one edge covered by the next blanket as shown in Figure 1A. The visible edges of the perimeter overlaps all point in the same direction.

1. One Layer 3M™ Fire Barrier Duct Wrap 615+
2. Steel Banding 1/2 in. (13 mm) Wide Min. Typical
3. 3 in. (76 mm) Min. Longitudinal Overlap

Figure 1A

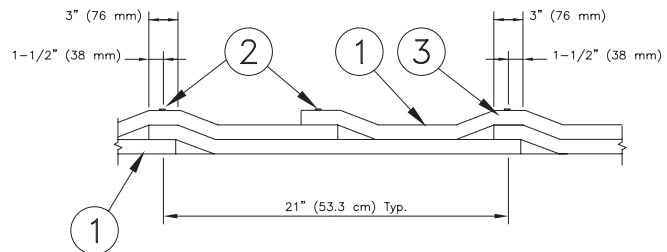

2. Checkerboard 3 in. (76 mm) Overlap Wrap Cross Section View

With the 3 in. (76 mm) checkerboard overlap wrap method, blankets with both edges exposed alternate with blankets with covered edges, as shown in Figure 1B. The visible edges of the perimeter overlaps alternate their directions and appear on every other blanket.

1. One Layer 3M™ Fire Barrier Duct Wrap 615+
2. Steel Banding 1/2 in. (13 mm) Wide Min. Typical
3. 3 in. (76 mm) Min. Longitudinal Overlap

Figure 1B

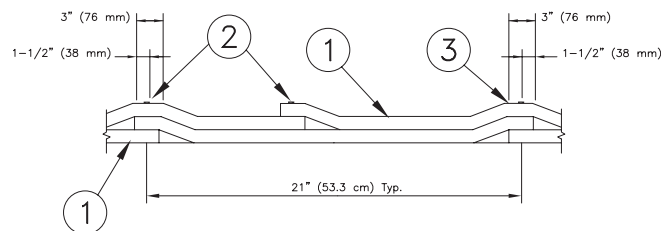

3. Butt Joint With Collar Cross Section View

With the butt joint and collar method, adjacent blankets are butted tightly together and 6 in. (152 mm) wide collar of duct wrap is centered over the joint, overlapping each blanket by 3 in. (76 mm) minimum as shown in Figure 1.

1. One Layer 3M™ Fire Barrier Duct Wrap 615+
2. Steel Banding 1/2 in. (13 mm) Wide Min. Typical
5. 6 in. (152 mm) Min. Wide 615+ or 20A Collar
6. Firmly Butted Joint

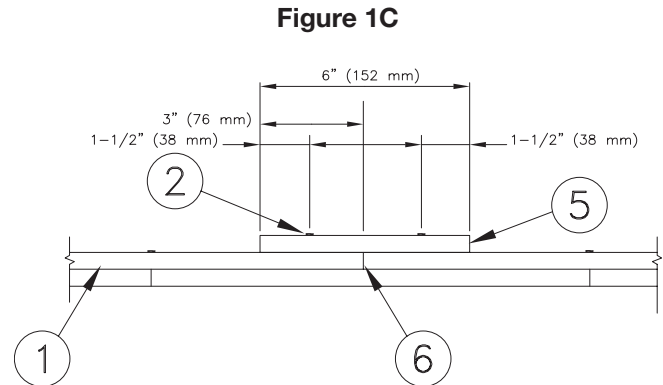

System integrity is limited by quality of installation.

Consult Current Independent Testing Laboratories (Intertek, UL) For Design or System Details.

In all three overlap techniques the perimeter overlap can occur at any location on the duct.

The blanket is mechanically attached to the duct by steel banding or by welded insulation pins and clips for all three installation methods listed above.

For Banding Only (See Figure 1)

Filament tape can be used to temporarily hold the blanket in place until the banding is applied. The steel banding is applied around the duct 1-1/2 in. (38 mm) from each edge of the blanket, and maximum 10-1/2 in. (26,7 cm) centers. The banding is placed around the material and tightened so as to sufficiently hold the 3M™ Fire Barrier Duct Wrap 615+ in place against the duct, compressing the foil but not cutting the foil.

Additional Pinning to Prevent Sagging of the Wrap

For Ducts 24 in. (60 cm) and larger in width, additional pins are needed to support the blanket on the bottom horizontal surface and on the outside face of a vertical duct run. Space pins a maximum of 10-1/2 in. (26,7 cm) apart in the direction of the blanket width, and a maximum of 12 in. (30 cm) apart in the direction of the blanket length. Refer to paragraph below for more information on Mechanical Fastening with Pins.

For Mechanical Fastening with Pins Only

Insulation pins are welded to the duct in the centers of the overlaps a minimum of 1-1/2 in. (38 mm) from each edge of the blanket, and spaced a maximum of 10-1/2 in. (26,7 cm) on center along perimeter overlap, and a maximum of 10-1/2 in. (26,7 mm) on center along longitudinal overlaps. The blanket is impaled over the pins and held in place by galvanized speed clips. Insulation pins that extend beyond the blanket wrap shall be turned down to eliminate sharp points. Insulated cup-head pins can be used at the same spacing requirements of the insulation pins.

NOTE: Support hangar systems do not need to be wrapped provided the hangar rods are at least a minimum of 3/8 in. (9,53 mm) diameter and spaced a maximum of 60 in. (152 cm) on center along the length of the duct. Use a minimum 2 in. x 2 in. x 1/4 in. (50 mm x 50 mm x 6,35 mm) steel angle steel support channel or SMACNA equivalent support system.

Figure 2

**3M™ Fire Barrier Duct Wrap 615+
Commercial Kitchen Grease Duct Systems
1 or 2 Hour Access Door System**

1. Access Hole
2. 1/4 in. (6 mm) Dia. All Threaded Rods
3. Access Cover – 16 Gauge
4. Insulation Pins – Welded
5. First Layer 3M™ Fire Barrier Duct Wrap 615+ Cut Same Size As Cover
6. Second Layer 3M™ Fire Barrier Duct Wrap 615+ with 1 in. (25 mm) Overlap On All Sides
7. Third Layer 3M™ Fire Barrier Duct Wrap 615+ with 1 in. (25 mm) Overlap On All Sides
8. Speed Clips
9. Aluminum Tape Covering All Exposed Edges
10. Spool Pieces For Threaded Rods
11. 1/4 in. (6 mm) Diameter Wings Nuts

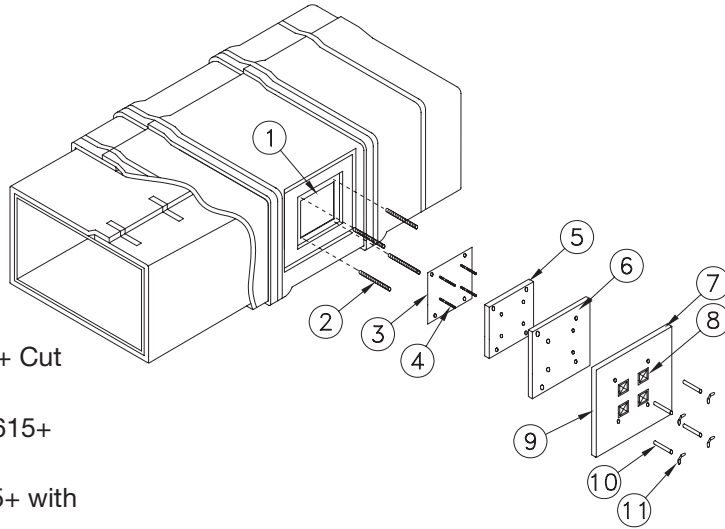

System integrity is limited by quality of installation.
Consult Current Independent Testing Laboratories
(Intertek, UL) For Design or System Details.

Access Door Installation

Four galvanized steel threaded rods, 1/4 in. diameter (6,35 mm) by 4-1/2 in. to 5 in. long (114 mm to 127 mm) are welded to the duct at the corners of the door opening. Four steel tubes, each 3 in. (76 mm) long, are placed over the rods to act as protection for the 3M™ Fire Barrier Duct Wrap 615+ when fastening the door. Four insulation pins are welded to the door panel for installation of the blanket. One layer of 3M™ Fire Barrier Duct Wrap 615+ is cut approximately the same size as the access panel and impaled over the insulation pins on the panel. *It is essential that this layer fit tightly against the wrap surrounding the access door opening with no through openings.* A second layer of 3M™ Fire Barrier Duct Wrap 615+ is cut so as to overlap the first layer by a minimum of 1 in. (25,4 mm). A third layer of 3M™ Fire Barrier Duct Wrap 615+ is cut so as to overlap the second layer by a minimum of 1 in. (25,4 mm). The third layer is impaled over the pins and all three layers are locked in place with galvanized or stainless steel speed clips. Pins that extend beyond the outer layer of 3M™ Fire Barrier Duct Wrap 615+ shall be turned down to avoid sharp points on the door. The insulated door panel is placed over the threaded rods and held in place with washers and wing nuts. The details are shown in Figure 2.

Figure 3

3M™ Fire Barrier Duct Wrap 615+ Commercial Kitchen Grease Duct Systems 1 or 2 Hour Through Penetration Systems 4-1/2 inch (11,4 cm) Concrete Floor or Wall

1. Floor/Ceiling or Wall Assembly
2. Duct
3. One or Two Layers 3M™ Fire Barrier Duct Wrap 615+
4. Banding or Pinning
5. Packing Material
6. 3M™ Fire Barrier Water Tight Sealant 1000 NS, 3M™ Fire Barrier Water Tight Sealant 1003 SL, or 3M™ Fire Barrier Silicon Sealant 2000+. For Wall Assembly Apply Sealant To Both Sides of Wall. 3M™ Fire Barrier Water Tight Sealant 1003 SL Not Suited For Wall Applications.

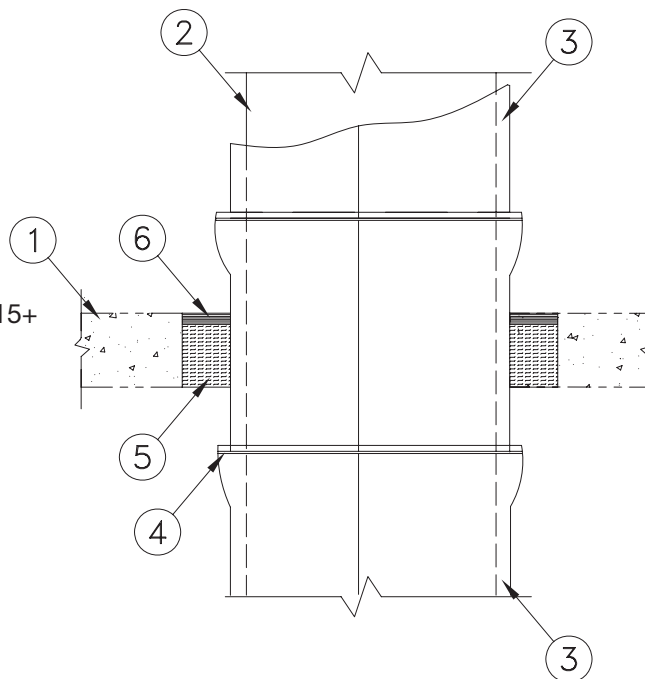

System integrity is limited by quality of installation.

Consult Current Independent Testing Laboratories (Intertek, UL) For Design or System Details.

Penetrations

When the duct penetrates a fire rated wall, ceiling or floor, an approved firestop system must be employed. Figure 3 illustrates a typical condition. To firestop the wrapped duct, follow the installation parameters detailed in a compatible ASTM E 814 tested through-penetration firestop design. **Note:** Through-penetration designs in which the duct is bare where it passes through combustible or limited-combustible construction (e.g. gypsum walls or wood joist floor-ceiling assemblies) are appropriate for ventilation duct scenarios only. It is not appropriate for bare, uninsulated grease ducts to pass through combustible assemblies.

Through Penetration Systems ASTM E 814		Intertek Testing Services			
Sealants	Fire Resistive Rating	Design Listing	(former OPL name)	Description	Firestopped To
3M™ Fire Barrier Water Tight Sealant 1000 NS	1 Hour	3MU/PH 60-01	FS 557 W	Gypsum Wall	Duct Wrap
		3MU/PV 60-01	FS 558 F	Floor-Ceiling	Duct Wrap
3M™ Fire Barrier Water Tight Sealant 1003 SL	2 Hour	3MU/PH 120-14	FS 559 W	Gypsum Wall	Duct Wrap
		3MU/PH 120-16	FS 563 W	Concrete Wall	Bare Duct
		3MU/PH 120-17	FS 566 W	Gypsum Shaft Wall	Bare Duct
		3MU/PH 120-18	FS 568 W	Gypsum Wall	Bare Duct
3M™ Fire Barrier Silicone Sealant 2000+		3MU/PH 120-29	FS 579 W	Concrete Wall	Duct Wrap
		3MU/PV 120-06	FS 576 F	Concrete Floor	Bare Duct
		3MU/PV 120-07	FS 578 F	Concrete Floor	Duct Wrap

For technical data and properties of 3M™ Fire Barrier Water Tight Sealant 1000 NS, 3M™ Fire Barrier Water Tight Sealant 1003 SL or 3M™ Fire Barrier Silicone Sealant 2000+, see separate product data sheets available from your 3M representative or go to www.3M.com/firestop.

This is only a partial list of design listings. For the latest information go to www.3M.com/firestop or speak to your authorized 3M distributor or sales representative at (800) 328-1687.

7. Maintenance

No maintenance is required when installed in accordance with the 3M Installation Instructions. Once installed, if any section of the 3M™ Fire Barrier Duct Wrap 615+ is damaged so that the blanket requires repair, the following procedures apply:

- The damaged section should be removed by cutting the steel banding or removing the clips holding it in place.
- A new section of the same dimension should be cut from a roll of 3M™ Fire Barrier Duct Wrap 615+, either 24 in. (60,9 cm) or 48 in. (121 cm) wide.
- The new section should be placed and fitted ensuring the same overlap that existed previously.
- The steel banding should be placed around the material and tensioned so as to sufficiently hold the 3M™ Fire Barrier Duct Wrap 615+ in place.
- If the blanket has not been damaged but the foil has ripped, seal the rips with aluminum foil tape.

8. Purchase Information

3M Fire Barrier products are available through a network of nationwide distributors. For information on where to buy, go to www.3M.com/firestop.

9. Safe Handling Information

Consult Material Safety Data Sheet prior to handling and disposing of 3M™ Fire Barrier Duct Wrap 615+.

Important Notice to User:

Product Use: Many factors beyond 3M's control and uniquely within user's knowledge and control can affect the use and performance of a 3M product in a particular application. Given the variety of factors that can affect the use and performance of a 3M product, user is solely responsible for evaluating the 3M product and determining whether it is fit for a particular purpose and suitable for user's method of application.

Warranty and Limited Remedy: 3M warrants that each 3M Fire Protection Product will be free from defects in material and manufacture for 90 days from the date of purchase from 3M's authorized distributor. 3M MAKES NO OTHER EXPRESS OR IMPLIED WARRANTIES, INCLUDING ANY IMPLIED WARRANTY OF MERCHANTABILITY OR FITNESS FOR A PARTICULAR PURPOSE. If a 3M product does not conform to this warranty, the sole and exclusive remedy is, at 3M's option, replacement of the 3M product or refund of the purchase price.

Limitation of Liability: Except where prohibited by law, 3M will not be liable for any loss or damage arising from the 3M product, whether direct, indirect, special, incidental or consequential, regardless of the legal theory asserted.





Material Safety Data Sheet

Copyright, 2010, 3M Company. All rights reserved. Copying and/or downloading of this information for the purpose of properly utilizing 3M products is allowed provided that: (1) the information is copied in full with no changes unless prior written agreement is obtained from 3M, and (2) neither the copy nor the original is resold or otherwise distributed with the intention of earning a profit thereon.

SECTION 1: PRODUCT AND COMPANY IDENTIFICATION

PRODUCT NAME: 3M(TM) Fire Barrier Duct Wrap 615+
MANUFACTURER: 3M
DIVISION: Building & Commercial Services Division
ADDRESS: 3M Center
St. Paul, MN 55144-1000

EMERGENCY PHONE: 1-800-364-3577 or (651) 737-6501 (24 hours)

Issue Date: 06/21/10
Supercedes Date: 09/01/09

Document Group: 27-3267-5

Product Use:

Intended Use: Passive Fire Protection

SECTION 2: INGREDIENTS

<u>Ingredient</u>	<u>C.A.S. No.</u>	<u>% by Wt</u>
Synthetic fibers, aluminum oxide-calcium oxide-magnesium oxide-silica	329211-92-9	> 95

SECTION 3: HAZARDS IDENTIFICATION

3.1 EMERGENCY OVERVIEW

Odor, Color, Grade: Grey-green, odorless material with a wool type appearance.

General Physical Form: Solid

Immediate health, physical, and environmental hazards:

3.2 POTENTIAL HEALTH EFFECTS

Eye Contact:

Dust created by cutting, grinding, sanding, or machining may cause eye irritation. Signs/symptoms may include redness, swelling, pain, tearing, and blurred or hazy vision.

Mechanical eye irritation: Signs/symptoms may include pain, redness, tearing and corneal abrasion.

Skin Contact:

Mechanical Skin irritation: Signs/symptoms may include abrasion, redness, pain, and itching.

Inhalation:

Dust from cutting, grinding, sanding or machining may cause irritation of the respiratory system. Signs/symptoms may include cough, sneezing, nasal discharge, headache, hoarseness, and nose and throat pain.

Dust from cutting, grinding, sanding or machining may cause target organ effects.

Ingestion:

No health effects are expected.

Carcinogenicity:

<u>Ingredient</u>	<u>C.A.S. No.</u>	<u>Class Description</u>	<u>Regulation</u>
GLASS FILAMENTS	SEQ753	Grp. 2B: Possible human carc.	International Agency for Research on Cancer
GLASS FILAMENTS	SEQ753	Anticipated human carcinogen	National Toxicology Program Carcinogens

SECTION 4: FIRST AID MEASURES

4.1 FIRST AID PROCEDURES

The following first aid recommendations are based on an assumption that appropriate personal and industrial hygiene practices are followed.

Eye Contact: Flush eyes with large amounts of water. If signs/symptoms persist, get medical attention.

Skin Contact: Wash affected area with soap and water. If signs/symptoms develop, get medical attention.

Inhalation: If signs/symptoms develop, remove person to fresh air. If signs/symptoms persist, get medical attention.

If Swallowed: No need for first aid is anticipated.

SECTION 5: FIRE FIGHTING MEASURES

5.1 FLAMMABLE PROPERTIES

Autoignition temperature	<i>Not Applicable</i>
Flash Point	<i>Not Applicable</i>
Flammable Limits - LEL	<i>Not Applicable</i>
Flammable Limits - UEL	<i>Not Applicable</i>

OSHA Flammability Classification:

Not Applicable

5.2 EXTINGUISHING MEDIA

Non-combustible. Choose material suitable for surrounding fire.

5.3 PROTECTION OF FIRE FIGHTERS

Special Fire Fighting Procedures: Wear full protective equipment (Bunker Gear) and a self-contained breathing apparatus (SCBA).

Unusual Fire and Explosion Hazards: Not applicable.

Note: See STABILITY AND REACTIVITY (SECTION 10) for hazardous combustion and thermal decomposition information.

SECTION 6: ACCIDENTAL RELEASE MEASURES

Personal precautions

Not applicable.

Environmental procedures

Not applicable.

Clean-up methods

Not applicable.

In the event of a release of this material, the user should determine if the release qualifies as reportable according to local, state, and federal regulations.

SECTION 7: HANDLING AND STORAGE

7.1 HANDLING

For industrial or professional use only. Avoid breathing of airborne material. Avoid breathing of dust created by cutting, sanding, grinding or machining.

7.2 STORAGE

Store away from acids.

SECTION 8: EXPOSURE CONTROLS/PERSONAL PROTECTION

8.1 ENGINEERING CONTROLS

Provide ventilation adequate to control dust concentrations below recommended exposure limits and/or control dust. Use general dilution ventilation and/or local exhaust ventilation to control airborne exposures to below Occupational Exposure Limits and/or control dust, fume, or airborne particles. If ventilation is not adequate, use respiratory protection equipment.

8.2 PERSONAL PROTECTIVE EQUIPMENT (PPE)

8.2.1 Eye/Face Protection

Avoid eye contact.

The following eye protection(s) are recommended: Safety Glasses with side shields
Indirect Vented Goggles

8.2.2 Skin Protection

Avoid prolonged or repeated skin contact. Gloves not normally required.

Select and use gloves and/or protective clothing to prevent skin contact based on the results of an exposure assessment. Consult with your glove and/or protective clothing manufacturer for selection of appropriate compatible materials.

Gloves made from the following material(s) are recommended: Neoprene
Nitrile Rubber

8.2.3 Respiratory Protection

Avoid breathing of dust created by cutting, sanding, grinding or machining. Under normal use conditions, airborne exposures are not expected to be significant enough to require respiratory protection.

Select one of the following NIOSH approved respirators based on airborne concentration of contaminants and in accordance with OSHA regulations: Half facepiece or fullface air-purifying respirator with N95 particulate filters

Consult the current 3M Respiratory Selection Guide for additional information or call 1-800-243-4630 for 3M technical assistance.

8.2.4 Prevention of Swallowing

Not applicable.

8.3 EXPOSURE GUIDELINES

<u>Ingredient</u>	<u>Authority</u>	<u>Type</u>	<u>Limit</u>	<u>Additional Information</u>
ANTIMONY COMPOUNDS	ACGIH	TWA, as Sb	0.5 mg/m3	
ANTIMONY COMPOUNDS	OSHA	TWA, as Sb	0.5 mg/m3	
ANTIMONY TRIOXIDE PRODUCTION	ACGIH	Limit value not established	****Missing Data**** No UOM specified or needed.	Cntrl all exposr-low as possib

SECTION 9: PHYSICAL AND CHEMICAL PROPERTIES

Odor, Color, Grade:	Grey-green,odorless material with a wool type appearance.
General Physical Form:	Solid
Autoignition temperature	<i>Not Applicable</i>
Flash Point	<i>Not Applicable</i>
Flammable Limits - LEL	<i>Not Applicable</i>
Flammable Limits - UEL	<i>Not Applicable</i>

Specific Gravity	2.5 - 3.0 [Ref Std: WATER=1]
Melting point	<i>Not Applicable</i>
Solubility in Water	Negligible
Percent volatile	0 %

SECTION 10: STABILITY AND REACTIVITY

Stability: Stable.

Materials and Conditions to Avoid:

10.1 Conditions to avoid

None known

10.2 Materials to avoid

Strong acids

Hazardous Polymerization: Hazardous polymerization will not occur.

Hazardous Decomposition or By-Products

Substance

Carbon monoxide
Carbon dioxide

Condition

Not Specified
Not Specified

SECTION 11: TOXICOLOGICAL INFORMATION

Please contact the address listed on the first page of the MSDS for Toxicological Information on this material and/or its components.

SECTION 12: ECOLOGICAL INFORMATION

ECOTOXICOLOGICAL INFORMATION

Not determined.

CHEMICAL FATE INFORMATION

Not determined.

SECTION 13: DISPOSAL CONSIDERATIONS

Waste Disposal Method: Dispose of waste product in a sanitary landfill. As a disposal alternative, dispose of waste product in a facility permitted to accept chemical waste.

EPA Hazardous Waste Number (RCRA): Not regulated

Since regulations vary, consult applicable regulations or authorities before disposal.

SECTION 14: TRANSPORT INFORMATION

ID Number(s):

98-0400-5589-3, 98-0400-5590-1

Please contact the emergency numbers listed on the first page of the MSDS for Transportation Information for this material.

SECTION 15: REGULATORY INFORMATION

US FEDERAL REGULATIONS

Contact 3M for more information.

311/312 Hazard Categories:

Fire Hazard - No Pressure Hazard - No Reactivity Hazard - No Immediate Hazard - Yes Delayed Hazard - No

STATE REGULATIONS

Contact 3M for more information.

CALIFORNIA PROPOSITION 65

Ingredient

GLASS FILAMENTS

C.A.S. No.

SEQ753

Classification

**Carcinogen

** WARNING: contains a chemical which can cause cancer.

CHEMICAL INVENTORIES

The components of this product are in compliance with the chemical notification requirements of TSCA.

This product is an article as defined by TSCA regulations, and is exempt from TSCA Inventory listing requirements.

Contact 3M for more information.

INTERNATIONAL REGULATIONS

Contact 3M for more information.

This MSDS has been prepared to meet the U.S. OSHA Hazard Communication Standard, 29 CFR 1910.1200.

SECTION 16: OTHER INFORMATION

NFPA Hazard Classification

Health: 1 Flammability: 0 Reactivity: 0 Special Hazards: None

National Fire Protection Association (NFPA) hazard ratings are designed for use by emergency response personnel to address the hazards that are presented by short-term, acute exposure to a material under conditions of fire, spill, or similar emergencies. Hazard ratings are primarily based on the inherent physical and toxic properties of the material but also include the toxic properties of combustion or decomposition products that are known to be generated in significant quantities.

HMIS Hazard Classification

Health: 1 Flammability: 0 Reactivity: 0 Protection: A

Hazardous Material Identification System (HMIS(r)) hazard ratings are designed to inform employees of chemical hazards in the workplace. These ratings are based on the inherent properties of the material under expected conditions of normal use and are not intended for use in emergency situations. HMIS(r) ratings are to be used with a fully implemented HMIS(r) program. HMIS(r) is a registered mark of the National Paint and Coatings Association (NPCA).

Revision Changes:

Copyright was modified.
Section 3: Potential effects from eye contact was modified.
Section 7: Handling information was modified.
Section 8: Engineering controls information was modified.
Section 8: Skin protection phrase was modified.
Section 8: Respiratory protection information was modified.
Section 13: Waste disposal method information was modified.
Section 8: Eye/face protection information was modified.
Section 8: Skin protection - recommended gloves information was modified.
Section 8: Respiratory protection - recommended respirators information was modified.
Section 1: Initial issue message was modified.
Section 12: Ecotoxicological phrase was modified.
Section 12: Chemical Fate phrase was modified.
Section 2: Ingredient table was modified.
Section 8: Exposure guidelines ingredient information was modified.
Section 3: Carcinogenicity table was added.
Section 3: Carcinogenicity heading was added.
Section 15: California proposition 65 ingredient information was added.
Section 15: California proposition 65 heading was added.
Section 15: California proposition 65 cancer warning was added.
Section 6: Environmental procedures heading was added.
Section 6: Personal precautions heading was added.
Section 10.1 Conditions to avoid heading was added.
Section 10.2 Materials to avoid heading was added.
Section 6: Personal precautions information was added.
Section 6: Environmental procedures information was added.
Section 6: Methods for cleaning up information was added.
Section 10: Materials to avoid physical property was added.
Section 10: Conditions to avoid physical property was added.
Section 8: Hand protection information was added.
Section 6: Clean-up methods heading was added.
Section 6: Release measures information was deleted.

Section 6: Release measures heading was deleted.
Section 10: Materials and conditions to avoid physical property was deleted.
Section 15: EPCRA 313 information was deleted.
Section 15: EPCRA 313 text was deleted.
Section 8: Exposure guidelines data source legend was deleted.

DISCLAIMER: The information in this Material Safety Data Sheet (MSDS) is believed to be correct as of the date issued. 3M MAKES NO WARRANTIES, EXPRESSED OR IMPLIED, INCLUDING, BUT NOT LIMITED TO, ANY IMPLIED WARRANTY OF MERCHANTABILITY OR FITNESS FOR A PARTICULAR PURPOSE OR COURSE OF PERFORMANCE OR USAGE OF TRADE. User is responsible for determining whether the 3M product is fit for a particular purpose and suitable for user's method of use or application. Given the variety of factors that can affect the use and application of a 3M product, some of which are uniquely within the user's knowledge and control, it is essential that the user evaluate the 3M product to determine whether it is fit for a particular purpose and suitable for user's method of use or application.

3M provides information in electronic form as a service to its customers. Due to the remote possibility that electronic transfer may have resulted in errors, omissions or alterations in this information, 3M makes no representations as to its completeness or accuracy. In addition, information obtained from a database may not be as current as the information in the MSDS available directly from 3M.

3M MSDSs are available at www.3M.com